

Helping a driver in backward docking with N-trailer vehicles by the passive control-assistance system

The paper presented during 16th IEEE Annual Conference on Intelligent Transportation Systems, pp. 1993-1999, Hague, Netherlands 2013, ©2013 IEEE

Maciej Michałek and Marcin Kielczewski

Abstract—The paper presents a control-assistance system devised for human drivers of articulated vehicles equipped with arbitrary number of trailers mounted in the *off-axle* manner. The proposed assistance system is *passive*, which means that it does not interact directly with a vehicle, but it only suggests control action to a human operator solely by a (passive) human-machine interface (HMI). In contrast to the *active* assistance systems proposed for N-trailers in the literature, the passive assistant does not require installation in a vehicle any high-end actuation subsystems like *steer-by-wire* or *cruise control*. The concept presented in the paper utilizes the cascaded VFO control law as a control-assistance function and the HMI with a simple and intuitive graphical interface, which allows a driver to focus an attention only on a single bar-like indicator. The system has been devised for N-trailer vehicles with a tractor of differentially-driven or car-like kinematics. Effectiveness of the assistance system has been illustrated by experimental results obtained with a laboratory-scale vehicle.

I. INTRODUCTION

Maneuvering with the tractor-trailers vehicles (N-trailers) is an extremely difficult task for a human operator. Due to specific properties of the N-trailer kinematics [1], the hand-made maneuvers performed even by experienced drivers are very burdening, non-intuitive and, in a consequence, dangerous. Difficulties increase (in a nonlinear fashion) with a number of trailers attached to a tractor. One of the most hard motion tasks for N-trailers are the backward parking maneuvers, where the last vehicle segment should be positioned at the desired location (the docking task) [18]. We consider the problem how to make this hard task simpler by application of a control-assistance system which could effectively cooperate with a human driver [8] (in contrast to the fully-autonomous control systems which completely replace a driver making a vehicle a robotic system [12], [11], [3]). For a single-body vehicles (commercial cars) such assistance systems have been widely proposed and are now commercially available (see the practical review [16]). However, for the multi-body vehicles the control-assistance systems for parking tasks are still under development. An example of the assistance system tested in a commercial truck with a limited number of trailers can be found in [17]; another kind of an assistance system, restricted however only to synchronization of a truck-trailer motion, can be found in [14]. Available solutions of control-assistance systems devised for N-trailers (especially those which admit arbitrary

number of trailers) are mainly focused on the active assistance concept [15], [13], [10]. In this approach the tractor must be equipped with the steer-by-wire implement and the cruise control system, which make the concept expensive and lead to legal problems in case of commercial applications. Mentioned consequences motivated research in the direction of passive control-assistance which can be applied into the N-trailers with conventional tractors equipped with the manual mechanical steering and acceleration/speed pedal. Examples of the passive parking assistants can be found in [9] for a single-body car and in [2] for a car-single-trailer vehicle.

In this paper we propose a passive control-assistance system which can be applied into N-trailers comprising of differentially-driven or car-like tractor and arbitrary number of trailers interconnected by passive rotary joints. The concept utilizes the cascaded Vector-Field-Orientation (VFO) feedback control strategy [6] which plays a role of a control assistant. Due to utilization of the VFO controller, which can smoothly guide a last vehicle segment toward desired location [4], any planning stage of the transient trajectory/path is not required. Control actions computed by the assistant are suggested to the driver by a very simple graphical human-machine interface (HMI), which allows a human focus an attention only on a single indicator during the whole parking process. This property makes the assistance system intuitive and easy to use allowing even unexperienced driver to successfully perform a docking task with the N-trailer. The concept will be described assuming the non-Standard N-Trailer (nSNT) kinematics of a vehicle where all the trailers are hitched with the non-zero hitching offsets (called the *off-axle* hitching). To the authors best knowledge, the passive assistance system for truly N-trailers has not been proposed in the literature.

II. PASSIVE CONTROL-ASSISTANCE – THE GENERAL CONCEPT AND PREREQUISITES

A general concept of the passive control-assistance can be explained by the block diagram presented in Fig. 1. We assume that in the system a human driver has an ability to affect a vehicle through the conventional interface in the form of a steering wheel and a speed pedal. Further, assume that the current vehicle configuration, represented by vector q , can be measured and it is available at the input of the *control assistant* block. This block computes the current control input (upon an appropriately selected control law) which should be applied to the vehicle in order to meet the control objectives imposed. The computed control input

This work was supported by the statutory grant No. 93/194/13 DS-MK. The authors are with Chair of Control and Systems Engineering, Poznan University of Technology, Piotrowo 3A, 60-965 Poznań, Poland, e-mail: maciej.michalek@put.poznan.pl

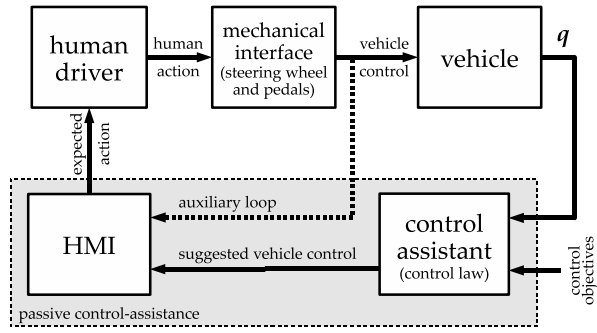

Fig. 1. A general concept of the passive control-assistance system (HMI – Human-Machine Interface)

is then suggested (by graphical, audio, haptic etc. forms) through the Human-Machine Interface (HMI) to a human driver indicating expected manual actions¹. A driver tries to track the suggestions from the HMI by forcing the control action through a mechanical interface available in the vehicle. Current reaction of the vehicle, reflected in a change of configuration q , allows updating the control suggestion in a feedback loop by the control assistant block. The main property of the above concept results from the fact that the assistance block does not interact directly with a vehicle [16] – all the responsibility of motion execution is left to a human driver, who may respect the assistant suggestions or not. This property makes the control-assistance system a *passive* solution.

Now, let us formulate some prerequisites which fix our attention more precisely on the problem under consideration. The N-trailer vehicle has been presented in Fig. 2. It consists of a tractor segment (numbered by zero index) and a number of N trailers interconnected by the passive rotary joints. The last trailer is a guiding segment (with the guidance point $P = (x_N, y_N)$) for which the docking task will be formulated. Kinematic parameters of the N-trailer are: trailer lengths $L_i > 0$ and hitching offsets $L_{hi} \in \mathbb{R}$, where $L_{hi} \neq 0$ for the off-axis hitching type and $L_{hi} = 0$ for the on-axis one [1], [4]. From now on we assume the special case of nSNT vehicle where $L_{hi} > 0$ for all $i = 1, \dots, N$ (every trailer is hitched *behind* a preceding wheel axle). Configuration of the vehicle can be represented by the vector:

$$\mathbf{q} \triangleq \begin{bmatrix} \boldsymbol{\beta} \\ \mathbf{q}_N \end{bmatrix} = [\beta_1 \dots \beta_N \ \theta_N \ x_N \ y_N]^\top, \quad (1)$$

where $\boldsymbol{\beta} \in \mathbb{T}^N$ is the joint-angle vector, and $\mathbf{q}_N \in \mathbb{S}^1 \times \mathbb{R}^2$ denotes the posture of the guidance segment. The tractor is the only active segment of a vehicle. It can be considered as a differentially-driven (DDV) or a car-like (CLV) vehicle. In the former case, the control input is defined as $\mathbf{u}_0 \triangleq [\omega_0 \ v_0]^\top \in \mathbb{R}^2$ with components interpreted as the angular and longitudinal velocities of the tractor, respectively. In the latter case, the control input can be defined as $\mathbf{w}_0 \triangleq [\omega_F \ v_F]^\top \in \mathbb{R}^2$ with components understood as the steering rate of the front wheel (F_0), $\omega_F = \dot{\beta}_0$, and the longitudinal

¹By the (optional) auxiliary loop depicted in Fig. 1 the HMI may be augmented with an additional control authority in order to compensate for the delay and inertia of the human driver dynamics.

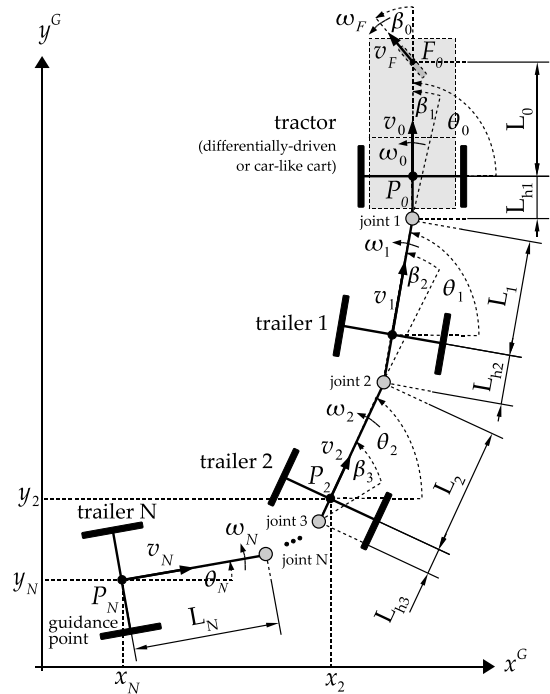

Fig. 2. N-trailer vehicle in a global frame with definitions of configuration variables and control inputs

velocity of the front wheel, respectively (front-wheel-driven cart, cf. Fig. 2). Correspondence between inputs \mathbf{u}_0 and \mathbf{w}_0 results from the well known kinematic relationships:

$$v_0 = v_F c \beta_0, \quad \omega_0 = \frac{1}{L_0} v_F s \beta_0, \quad \dot{\beta}_0 = \omega_F, \quad (2)$$

where $L_0 > 0$ denotes the length of the car-like tractor, and $s\alpha \equiv \sin \alpha$, $c\alpha \equiv \cos \alpha$.

Having defined the configuration and control variables of the N-trailer we can precisely formulate the control objective we are interested in (the docking task) which should be provided to the control assistant block in Fig. 1. Let $\mathbf{q}_{Nd} = [\theta_{Nd} \ x_{Nd} \ y_{Nd}]^\top$ denote the constant reference posture for the guiding segment, and let

$$\mathbf{e}_w(t) \triangleq \mathbf{W} \mathbf{e}(t), \quad \mathbf{e}(t) = \begin{bmatrix} e_\theta \\ e_x \\ e_y \end{bmatrix} \triangleq \mathbf{q}_{Nd} - \mathbf{q}_N(t) \quad (3)$$

be the weighted posture error, where $\mathbf{W} \triangleq \text{diag}\{w, 1, 1\}$ and $w \in [0, 1]$. The control objective is to compute a control input $\mathbf{u}_0 = \mathbf{u}_0(\mathbf{e}, \boldsymbol{\beta})$ which guides the last trailer posture \mathbf{q}_N toward the reference point \mathbf{q}_{Nd} with some prescribed precision $\delta \geq 0$ in the sense:

$$\forall t \geq T \ \|\mathbf{e}_w(t)\| \leq \delta, \quad (4)$$

where $T \in (0, \infty)$ is the docking time-horizon. Formulation of the above objective in terms of input \mathbf{u}_0 does not diminish its generality, since the corresponding car-like input \mathbf{w}_0 can be inferred from relations (2) – see [7] and Section III-B.

III. PASSIVE CONTROL-ASSISTANCE FOR N-TRAILERS

The passive control-assistance system will be described sequentially. First, a control law chosen for a role of a control

assistant will be shortly recalled and its selection for the nSNT vehicles will be justified. Second, utilization of the control assistant in the overall passive assistance system will be explained for the case where a tractor of the N-trailer has got car-like kinematics. The role and working principles of the HMI interconnecting the assistant subsystem with the human-control subsystem will be clarified.

A. Cascaded VFO control law as the control assistant

For the purpose of a control assistant we have selected the cascaded VFO control law formulated for the set-point control task in [4] – we briefly recall and explain the fundamental relations below. For our purposes let us treat any i th segment of the N-trailer vehicle as the unicycle ($i = 0, 1, \dots, N$)

$$\begin{bmatrix} \dot{\theta}_i \\ \dot{x}_i \\ \dot{y}_i \end{bmatrix} = \begin{bmatrix} 1 & 0 \\ 0 & c\theta_i \\ 0 & s\theta_i \end{bmatrix} \mathbf{u}_i, \quad \mathbf{u}_i \triangleq \begin{bmatrix} \omega_i \\ v_i \end{bmatrix} \quad (5)$$

with velocity vector $\mathbf{u}_i \in \mathbb{R}^2$, which can be treated as the virtual control input of the i th segment. It is not hard to find that velocities of any two interconnected segments are related through transformation

$$\mathbf{u}_i = \mathbf{J}_i(\beta_i) \mathbf{u}_{i-1} = \begin{bmatrix} -\frac{L_{hi}}{L_i} c\beta_i & \frac{1}{L_i} s\beta_i \\ L_{hi} s\beta_i & c\beta_i \end{bmatrix} \begin{bmatrix} \omega_{i-1} \\ v_{i-1} \end{bmatrix}, \quad (6)$$

which can be applied along a vehicle kinematic chain yielding the *velocity propagation formula*

$$\mathbf{u}_i = \prod_{j=i}^1 \mathbf{J}_j(\beta_j) \mathbf{u}_0, \quad i = 1, \dots, N. \quad (7)$$

The above equation explains how input \mathbf{u}_0 of the differentially-driven tractor affects velocities of the i th vehicle segment. In case of nSNT vehicles, where all the hitching offsets $L_{hi} \neq 0$, one can formulate the inverse velocity transformation

$$\mathbf{u}_{i-1} = \mathbf{J}_i^{-1}(\beta_i) \mathbf{u}_i = \begin{bmatrix} -\frac{L_i}{L_{hi}} c\beta_i & \frac{1}{L_{hi}} s\beta_i \\ L_i s\beta_i & c\beta_i \end{bmatrix} \begin{bmatrix} \omega_i \\ v_i \end{bmatrix}, \quad (8)$$

which can be applied along a vehicle kinematic chain yielding the *velocity inverse-propagation formula*

$$\mathbf{u}_{i-1} = \prod_{j=i}^N \mathbf{J}_j^{-1}(\beta_j) \mathbf{u}_N, \quad i = 1, \dots, N. \quad (9)$$

Eq. (9) for $i = 1$ takes the form $\mathbf{u}_0 = \prod_{j=1}^N \mathbf{J}_j^{-1}(\beta_j) \mathbf{u}_N$. The latter equation may suggest how to design the tractor input \mathbf{u}_0 in order to force a desired virtual input \mathbf{u}_N on the last trailer (guidance segment). Using this suggestion we propose to define the control input as follows

$$\mathbf{u}_{0c}(e, \beta) \triangleq \prod_{j=1}^N \mathbf{J}_j^{-1}(\beta_j) \Phi(e), \quad (10)$$

where index 'c' denotes the term 'computed' according to the above strategy. We postulate that $\Phi(e) = [\Phi_\omega(e) \ \Phi_v(e)]^\top \in \mathbb{R}^2$ is some feedback control function (defined explicitly in the sequel) which guarantees convergence of the posture error

(3) to zero when it is directly applied into virtual input \mathbf{u}_N of the unicycle-like guiding segment. It is almost immediately clear that, by taking $\mathbf{u}_0 := \mathbf{u}_{0c}(e, \beta)$ and using (7) for $i = N$, one obtains $\mathbf{u}_N = \Phi(e)$, which allows satisfaction of the asymptotic-convergence postulate mentioned above (see [4]). Note that (10) has a form of the cascaded control law, where the outer-loop controller is determined by function $\Phi(e)$, and the inner feedback loop is represented by the velocity inverse-propagation formula.

Now, let us explicitly define the outer-loop control function $\Phi(e)$, which results from the geometrically-motivated VFO strategy (cf. [4], [6] and [5])

$$\Phi(e) = \begin{bmatrix} \Phi_\omega(e) \\ \Phi_v(e) \end{bmatrix} \triangleq \begin{bmatrix} k_a(\theta_{Na} - \theta_N) + \dot{\theta}_{Na} \\ \|\bar{e}\|^\gamma c\alpha \end{bmatrix}, \quad (11)$$

with $\|\bar{e}\| \triangleq \sqrt{e_x^2 + e_y^2}$ and

$$\theta_{Na} \triangleq \text{Atan2c}(\sigma \cdot h_y, \sigma \cdot h_x) \in \mathbb{R}, \quad (12)$$

$$\dot{\theta}_{Na} = (\dot{h}_y h_x - h_y \dot{h}_x) / (h_x^2 + h_y^2), \quad (13)$$

$$h_x \triangleq k_p e_x - \eta \sigma \|\bar{e}\| c\theta_{Nd}, \quad (14)$$

$$h_y \triangleq k_p e_y - \eta \sigma \|\bar{e}\| s\theta_{Nd}, \quad (15)$$

$$c\alpha \triangleq (h_x c\theta_N + h_y s\theta_N) / \sqrt{h_x^2 + h_y^2}, \quad (16)$$

where $\text{Atan2c}(\cdot, \cdot) : \mathbb{R} \times \mathbb{R} \mapsto \mathbb{R}$ is a continuous version of the four-quadrant function $\text{Atan2}(\cdot, \cdot) : \mathbb{R} \times \mathbb{R} \mapsto [-\pi, \pi]$. In definitions (11)-(15) we have introduced four design parameters $k_a, k_p > 0$, $\eta \in (0, k_p)$, $\gamma \in [0, 1)$, and decision factor $\sigma \in \{-1, +1\}$ which determines a motion strategy (forward/backward) for the guiding segment – for backward maneuvers one should take $\sigma = -1$. Selection of the VFO controller is justified by the beneficial and intuitive transient behavior which it guarantees (with the so-called *directing effect* yielding the non-oscillatory and monotonous terminal approaching to a reference posture), and by simple implementation and tuning of the controller. Interpretation of the VFO equations, detailed comments on the controller parametric synthesis, and analysis of the joint-angles behavior in the closed-loop system can be found in [6], [4], [5]. To avoid unnecessary repetitions of our prior works let us restrict further comments on application of the above strategy to the corollary which summarizes the closed-loop system behavior comprised of the nSNT vehicle with a differentially-driven tractor and with the control input determined by (10)-(11).

Corollary 1: Let us assume that $L_{hi} > 0$ for all $i = 1, \dots, N$ (nSNT vehicle with every hitching point located *behind* a wheel-axle of a preceding vehicle segment). Then, application of the cascaded VFO controller (10)-(11) with $\sigma = -1$ (backward parking maneuvers) such that

$$\mathbf{u}_0 := \begin{cases} \mathbf{u}_{0c}(e, \beta) & \text{when } \|e_w\| > \delta \\ \mathbf{0} & \text{when } \|e_w\| \leq \delta \end{cases} \quad (17)$$

guarantees that $\|\beta(t)\|$ and a norm of error (3) remain bounded for all $t \geq 0$, and the objective (4) is satisfied with $T = T(\delta)$.

Obviously, we are not interested here in the direct application of the presented control law into a vehicle (we do not consider autonomous parking). Instead, the control action, being permanently computed in the control-assistance block upon definition (17), should be suggested to a driver in some acceptable manner by taking into account perception limitations of a human operator. In this context, we propose in the next section an interface interconnecting the control-assistance block with a human-control subsystem.

B. Interface between the control-assistance and human-control subsystems for N -trailers with a car-like tractor

To the design purposes we assume that a driver has got at his/her disposal two (human) control-actions: change of the steering-wheel angle β_0 and selection (by a pedal) of the longitudinal velocity v_F of a front tractor wheel. Let us consider a way in which the control input $\mathbf{u}_{0c}(\mathbf{e}, \boldsymbol{\beta})$, computed and suggested by the assistant, can be effectively reproduced by the driver.

At any time instant, the control assistant provides the two-dimensional vector of control actions $\mathbf{u}_{0c}(\mathbf{e}, \boldsymbol{\beta}) = [\omega_{0c}(\mathbf{e}, \boldsymbol{\beta}) \ v_{0c}(\mathbf{e}, \boldsymbol{\beta})]^\top$. According to the control objective stated in Section II, the most important issue is to track the instantaneous 'computed' motion curvature of a tractor κ_c , which directly results from the computed control vector

$$\kappa_c(\mathbf{e}, \boldsymbol{\beta}) = \frac{\omega_{0c}(\mathbf{e}, \boldsymbol{\beta})}{v_{0c}(\mathbf{e}, \boldsymbol{\beta})} \in \mathbb{R}. \quad (18)$$

Thus, following the instantaneous curvature determined by (18) guarantees reproduction of the suggested motion geometry and, in a consequence, realization of the docking task. Note that in case of parking maneuvers the longitudinal speed of motion realization has a secondary meaning. Moreover, it should be freely regulated by a human operator according to the personal preferences and driving skills. Due to the mentioned reasons we will exclude the longitudinal speed suggestions from the HMI in order to not burden a driver unnecessarily.

Recalling (2) one finds simple relation joining the curvature of the tractor body and the steering angle of a front wheel:

$$\kappa = \frac{\omega_0}{v_0} \stackrel{(2)}{=} \frac{1}{L_0} \tan \beta_0. \quad (19)$$

By substitution of (18) into the left-hand side of (19) one can propose a definition of the 'computed' (and suggested) angle of a steering wheel of a car-like tractor in the form (alternative definitions can be found in [7])

$$\beta_{0c} \triangleq \begin{cases} \text{Atan2}(\nu L_0 \omega_{0c}, \nu v_{0c}) & \text{for } \|\mathbf{u}_{0c}\| > 0 \\ 0 & \text{for } \|\mathbf{u}_{0c}\| = 0 \end{cases}, \quad (20)$$

where $\text{Atan2}(\cdot, \cdot) : \mathbb{R} \times \mathbb{R} \mapsto [-\pi, \pi)$, and $\nu \triangleq \text{sgn}(v_F)$ depends on a sign of the speed selected by a driver through a pedal. Coefficient ν determines the quadrant of the desired steering angle. From now on we assume that the speed v_F forced by a driver is always non-positive. This assumption (leading to $\nu = -1$) comes solely from pragmatic reasons, since the smooth human-acceptable backward maneuvers

should not involve reversing of the tractor motion. Note that according to this assumption β_{0c} will belong to the first or fourth quadrant if $v_{0c} < 0$, and to the second or third quadrant if $v_{0c} > 0$ ². Note that in the latter case (and for $\beta_0 \approx \beta_{0c}$) the longitudinal velocity v_0 becomes positive (see the first equation in (2)), thus its sign remains compatible with the control-assistant suggestion. Summarizing, we have got only a single variable β_{0c} which should be suggested to a driver during parking maneuvers. Hence, the HMI may be limited only to a single indicator devoted to the steering-wheel angle determined by (20), leaving realization of the instantaneous velocity v_F as a free driver disposal. The above concept seems to be practically reasonable when considering perception limitations of an average human driver.

The scheme of the overall proposed passive control-assistance system has been illustrated in Fig. 3. The interface described above consists of the conversion block (denoted by conversion symbol DDV \rightarrow CLV in Fig. 3) and the HMI interface which is responsible for on-line indication of the suggested steering angle β_{0c} and the current steering angle β_0 (the latter in order to provide a feedback from efficiency of a human action). Description of the HMI design is included in Section IV-B.

IV. LABORATORY-SCALE EXPERIMENTS

A. Experimental testbed

The passive control-assistance system has been implemented on the laboratory *RMP-Assistant* testbed according to the block scheme shown in Fig. 4. On the scheme, one may distinguish two physically separated subsystems: the vehicle subsystem (VS) and the human-control subsystem (HS). VS consists of the 3-trailer (laboratory-scale) *RMP* vehicle (presented in Fig. 5), the control-assistant, and the auxiliary blocks used for vehicle localization improvements and for on-line input scaling purposes (the latter in order to limit the inputs to the admissible levels resulting from maximal admissible velocity $\omega_{w \max}$ of the tractor wheels, see [6]). Joint angles of the *RMP* vehicle are measured by the 14-bit absolute encoders. Localization of the guidance segment has been computed as a linear weighted combination (cf. Fig. 4) $\hat{\mathbf{q}}_N = w_1 \hat{\mathbf{q}}_{Np} + w_2 \hat{\mathbf{q}}_{Nv}$ with the user-selectable weights satisfying $w_1 + w_2 = 1$. All the computational blocks in the VS have been implemented on the DSP on-board controller (processor TMS320F28335) and have been executed with a sampling time $T_p = 0.01$ s. The human-control subsystem consists of a human operator with a mechanical interface (Logitech steering wheel with pedals), a HMI panel, and two conversion blocks (denoted by DDV \rightarrow CLV and CLV \rightarrow DDV). Transformation block denoted by CLV \rightarrow DDV has been introduced because the real tractor of *RMP* vehicle has the unicycle-like kinematics, while we want to make it mimic the car-like behavior according to the equations provided in (2).

²Positive velocity v_{0c} may temporarily be suggested by the control assistant when substantial reconfiguration maneuvers of a vehicle chain are required during a docking process.

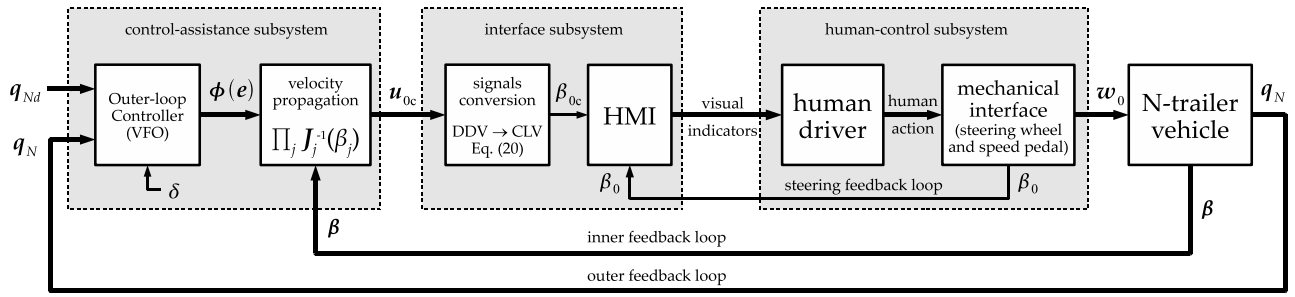

Fig. 3. Block scheme of the proposed passive control-assistance system for N-trailer vehicles with a tractor of car-like kinematics

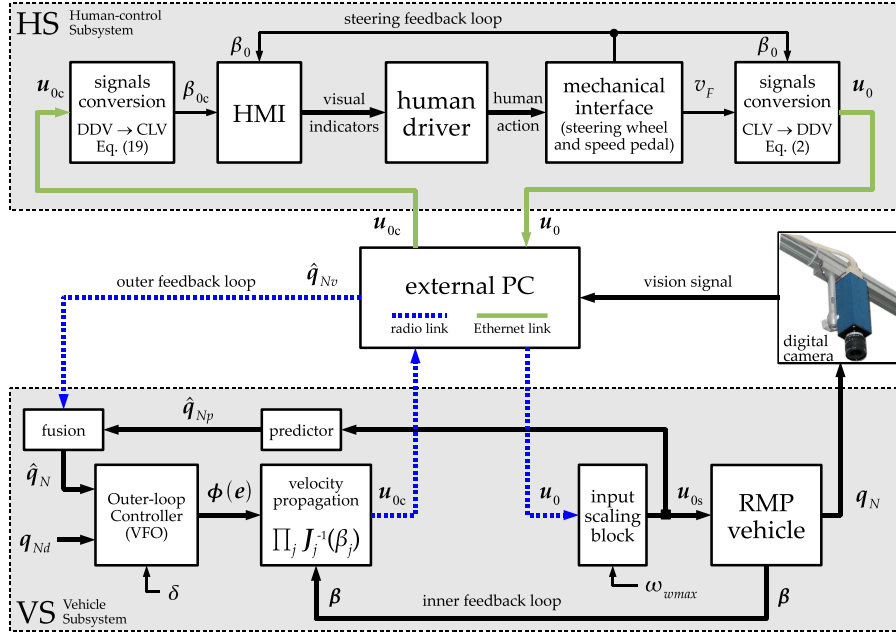

Fig. 4. Implementation scheme of the passive control-assistance system in the experimental *RMP-Assistant* testbed

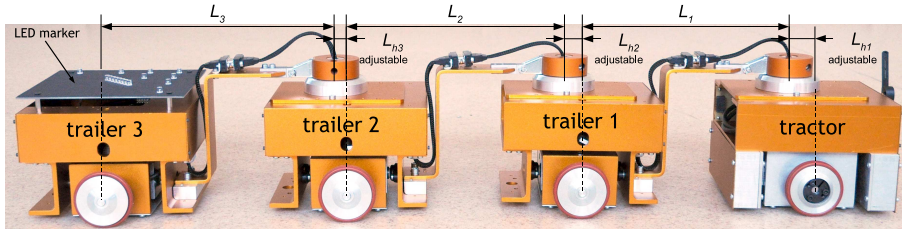

Fig. 5. 3-trailer *RMP* vehicle with adjustable hitching offsets and with a differentially-driven tractor

VS and HS have been interconnected by an external PC station which plays (together with an external digital camera) a role of the exteroceptive vehicle localization system (visual detection is based on a LED marker situated on the guiding segment, see Fig. 5). Besides, the PC computer is responsible for intercommunication between the two subsystems (by the radio and Ethernet links).

B. Description of the human-machine interface

The graphical human-machine interface used on the experimental testbed has been illustrated in Fig. 6. It has been designed under assumption of the minimal human-machine

interaction, where the only two red parallel graphical bars indicate the computed steering angle β_{c0} and the current steering angle β_0 , respectively (the latter directly related to the position of a steering-wheel). A driver must track a value of β_{c0} by observing the bars on a HMI screen and by manipulating the steering wheel. Longitudinal velocity v_F (commanded by a pedal) can be set arbitrarily by a driver; it can be even time-varying (usually small values of the speed are recommended to keep variability of β_{c0} on the acceptable level – it depends on the personal perceptual-motoric properties of a driver). The small square-indicator, marked as *Goal reached*, signals completion of a parking

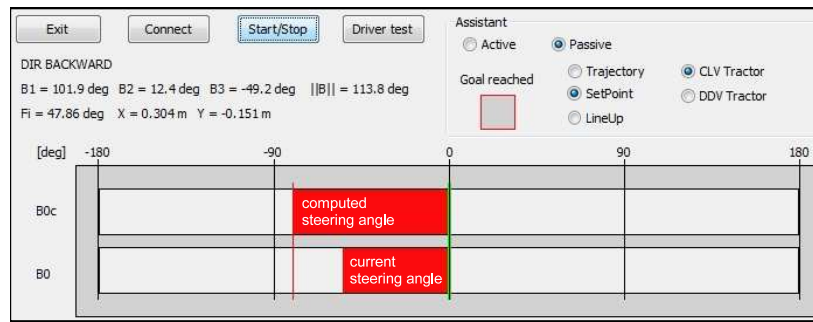

Fig. 6. View of the graphical HMI used on the *RMP-Assistant* testbed

task when it is highlighted in green.

C. Exemplary experimental results

Three experimental tests of manual backward parking maneuvers have been conducted with a help of the control assistant for different numbers of trailers attached to the tractor of *RMP* vehicle: experiment A for a single trailer, B for two trailers, and experiment C for three trailers. For particular vehicle segments kinematic parameters were selected as follows: $L_0 = 0.17$ m, $L_i = 0.229$ m and $L_{hi} = 0.048$ m, $i = 1, 2, 3$. In all cases the control objective was to dock the last trailer at reference posture $\mathbf{q}_{Nd} := \mathbf{0}$. Following common parameters of the control assistant have been selected: $k_a = 2$, $k_p = 1$, $\gamma = 0.4$, $\sigma = -1$, $w = 0.001$, $\delta = 0.02$, $\omega_{w_{\max}} = 8$ rad/s, $w_1 = 0.98$, $w_2 = 0.02$ (in order to enhance terminal attenuation of the measurement noise level the weights were switched into $w_1 = 1$ and $w_2 = 0$ in the vicinity of 0.08 m near the reference position). Values of parameter η have been equal to 0.8, 0.8, and 0.6, respectively, for particular experiments. Only negative longitudinal velocity v_F was being applied by a driver with a mechanical pedal ($\nu = -1$). The results of tests A, B, and C have been illustrated in Figs. 7-8. Apart from the X-Y plots, time-plots of the joint angles, posture error components, steering-wheel angles (computed one, β_{0c} , and β_0 achieved by the manual steering action), and tractor velocities have been presented.

Analyzing the plots one can observe that in all the cases successful and relatively smooth vehicle motion have been obtained. Worth to note that the docking tasks have been performed by a driver without any professional experience in tractor-trailers maneuvers. Comparing the results of three experiments one can find that difficulty of maneuvers, reflected in the degree of oscillatory steering-wheel motion and in the docking time-horizon, increases with a number of trailers attached to the tractor. Worth to note however, that successful maneuvers for conditions of experiments B and C were virtually impossible for a driver without the help of the proposed control-assistant system.

V. CONCLUSIONS

In the paper the passive control-assistance system for backward docking with N-trailer vehicles has been proposed and experimentally verified. Some beneficial features of the

proposed solution seem to deserve an attention. First, worth to mention high scalability of the control assistant algorithm, where a number of trailers attached to a vehicle influences only a number of matrix multiplications in equation (10). Second, simplicity of the cascaded VFO control law implementation and tuning [6] allows it to be embedded into a low-cost on-board processing unit. Third, the human-machine interface proposed is simple and intuitive enabling a driver to successfully accomplish difficult maneuvers by focusing attention only on a single bar-like indicator.

There still remain some important open problems which should be treated like consideration of mechanical limitations imposed on vehicle joints and on a steering angle usually present in car-like tractors, and elaboration of the low-cost (but reliable) measurement method for the joint angles which would be more suitable in the case of full-scale articulated vehicles. Applicability extension of the proposed scheme into N-trailer vehicles with the mixed off-axle and on-axle hitched trailers will be a topic of the authors' near-future works.

REFERENCES

- [1] C. Altafini. Some properties of the general n-trailer. *International Journal of Control*, 74(4):409–424, 2001.
- [2] E. Balcerak, J. Schikora, P. Wojke, and D. Zöbel. Maneuver-based assistance for backing up articulated vehicles. In *Proc. of the 2004 IEEE Conf. on Robotics, Automation and Mechatronics*, pages 1066–1071, Singapore, 2004.
- [3] C. Cariou, R. Lenain, B. Thuilot, and P. Martinet. Path following of a vehicle-trailer system in presence of sliding: application to automatic guidance of a towed agricultural implement. In *The 2010 IEEE/RSJ Int. Conf. Intel. Robots and Systems*, pages 4976–4981, Taiwan, 2010.
- [4] M. Michalek. Application of the VFO method to set-point control for the N-trailer vehicle with off-axle hitching. *International Journal of Control*, 85(5):502–521, 2012.
- [5] M. Michalek and K. Kozłowski. Finite-time VFO stabilizers for the unicycle with constrained control input. In *Robot Motion and Control 2009*, volume 396 of *Lecture Notes in Control and Information Sciences*, pages 23–34. Springer, 2009.
- [6] M. Michalek and K. Kozłowski. Vector-Field-Orientation feedback control method for a differentially driven vehicle. *IEEE Transactions on Control Systems Technology*, 18(1):45–65, 2010.
- [7] M. Michalek and K. Kozłowski. Feedback control framework for car-like robots using the unicycle controllers. *Robotica*, 30:517–535, 2012.
- [8] A. Eskandarian. Fundamentals of driver assistance. In A. Eskandarian, editor, *Handbook of Intelligent Vehicles*, pages 829–864. Springer, London, 2012.
- [9] M. Hirokawa, N. Uesugi, S. Furugori, T. Kitagawa, and K. Suzuki. A haptic instruction based assisted driving system for training the reverse parking. In *2012 IEEE Int. Conf. Robotics and Automation*, pages 3713–3718, Saint Paul, USA, 2012.

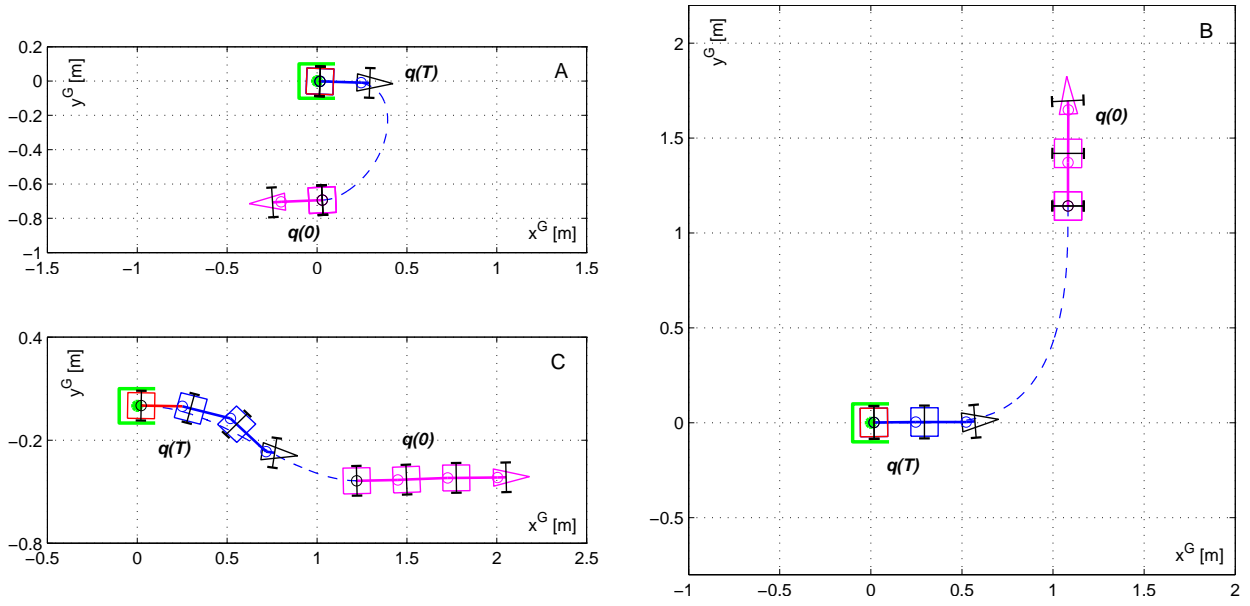

Fig. 7. The results of *U-turn docking* (A), *perpendicular docking* (B), and *parallel docking* (C); by $q(0)$ and $q(T)$ the initial and terminal vehicle configurations have been denoted, respectively

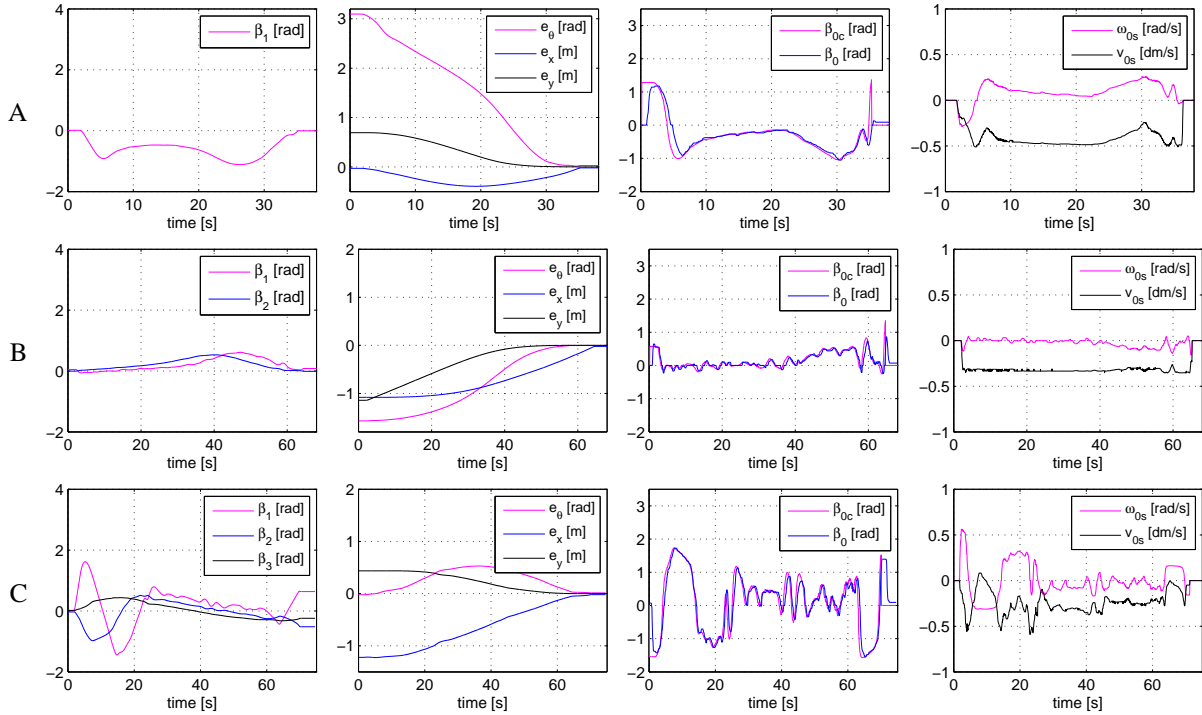

Fig. 8. Time plots of selected signals for experiments A, B, and C, respectively (velocities ω_{0s} and v_{0s} are the components of scaled vehicle control-input u_{0s} denoted in Fig. 4)

- [10] C. R. Kelber, F. S. Osório, and L. B. Becker. Assistance controller for driving backwards and parking an articulated vehicle. In *2008 IEEE Intell. Vehicles Symposium*, pages 1045–1049, Eindhoven, The Netherlands, 2008.
- [11] O. Lefebvre and F. Lamiroux. Docking task for nonholonomic mobile robots. In *Proceedings of the 2006 IEEE International Conference on Robotics and Automation*, pages 3736–3741, Orlando, USA, 2006.
- [12] Z. Leng and M. Minor. A simple tractor-trailer backing control law for path following. In *2010 IEEE/RSJ Int. Conf. on Intell. Robots and Systems*, pages 5538–5542, Taipei, Taiwan, 2010.
- [13] J. Morales, A. Mandow, J. L. Martinez, and A. J. Garcia-Cerezo. Driver assistance system for backward maneuvers in passive multi-trailer vehicles. In *2012 IEEE/RSJ Int. Conf. on Intell. Robots and Systems*, pages 4853–4858, Vilamoura, Portugal, 2012.
- [14] A. M. C. Odhams, R. L. Roebuck, B. A. Ujnovich, and D. Cebon. Active steering of a tractor-semi-trailer. *Proc. IMechE, Part D*, 225:847–869, 2010.
- [15] J. I. Roh and W. Chung. Reversing control of a car with a trailer using the driver assistance system. *Int. J. Advanced Robotic Systems*, 8(2):114–121, 2011.
- [16] M. Seiter, H.-J. Mathony, and P. Knoll. Parking assist. In A. Eskandarian, editor, *Handbook of Intelligent Vehicles*, pages 829–864. Springer, London, 2012.
- [17] R. Stahn, G. Heiserich, and A. Stopp. Laser scanner-based navigation for commercial vehicles. In *Proc. 2007 IEEE Intell. Vehicles Symposium*, pages 969–974, Istanbul, Turkey, 2007.
- [18] D. Zöbel. Trajectory segmentation for the autonomous control of backward motion for truck and trailer. *IEEE Trans. Intel. Transportation Systems*, 4(2):59–66, 2003.